



**rewaco**<sup>®</sup> *refreshes your life.*



**The new dimension.**



At the beginning was the idea of developing a vehicle with the character of a trike and the characteristics of a sports car, but not without the most important thing, the unrestricted view of the road. We have realized our dream and it has never been more exciting to feel the wind.

A serious torque, water-cooled 16-valve engine is the heart of the new RF1 trike series. With a specific weight of the engine of 5 kg per hp, the RF1 is superior to most sports cars with 250 hp or more in the spurt.

The sporty chassis, the spurt-strong engine with its low centre of gravity and the steadfast disc brake system are the guarantee for driving dynamics and safety.





The 4-cylinder in-line engine is imbedded transverse to the vehicle axis as a centre engine in a tube frame. This light and very torsion-resistant frame construction allows you to enjoy the driving fun of this powerful trike.

The full and sonorous sound of the stainless steel exhaust and the deep

intake sound of the high flow air filter system turn each ride into a special sound experience.

Do a test drive and see how much performance and safety the new RF1 by **rewaco** has to offer.

**Driving fun of the new dimension.**



## Standard equipment

### Engine

- 1.6 ltr. 4-cylinder in-line engine (16 valves) with 85 kW [115 hp]
- Sport exhaust in stainless steel
- Sport air filter and fan-type manifold

### Chassis

- *Sportline* steering fork of stainless steel
- Bilstein gas pressure shock absorbers
- Front tyre 180/55 ZR 17 on 5 J alu. spoke rim
- Rear tyres 275/40 ZR 17 on aluminum rim 10 J
- Brake booster
- Perforated stainless steel brake disk, front
- Brake disc, rear

### Body

- GRP\* in plain colour: Ruby-Red and Melon-Yellow
- Integrated boot and glove compartment
- Headlights and additional headlights
- Voltmeter and water temperature indicator
- Day odometer
- Brake and clutch pedal adjustment

## Optional equipment

### Chassis

- Front tyre 200/50 ZR 17 on 3-piece aluminum rim 5,5 J
- Rear tyres 285/35 ZR 18 on 3-piece aluminum rim 11 J
- Rear tyres 335/30 ZR 18 on 3-piece aluminum rim 12 J

### Body

- Roadster handle of stainless steel
- Spoiler
- Leather arm pads for passenger
- Side impact protection of stainless steel
- Varnish from the **rewaco** colour range: Reflex-Silver, Panther-Black, Brilliant-White, Electric-Orange, Ruby-Red, Racing-Blue, all in pearl effect and Chameleon Colour
- Luggage rack
- Footrests for passenger
- Trailer hitch

\* glass-fibre reinforced plastic



**1**  
**Side support**  
Sport seats with anatomical fit



**2**  
**Dynamics**  
Stainless steel sport exhaust and air filter deliver an acoustic experience



**3**  
**Generous space**  
Boot with more than 200 ltr. capacity and practical glove compartment



**4**  
**Grip**  
Wheels rear aluminium rim 275/40 ZR 17 and front aluminium spoke wheel 180/55 ZR 17



**5**  
**High Performance**  
Wheels rear 285/35 ZR 18 or 335/30 ZR 18 and front wheel 200/50 ZR 17



**6**  
**Individuality**  
The rear spoiler offers a compact and sporty note

GTT





## Bodywork colours



● Melon-Yellow  
(GRP\*-colour)



■ Brilliant-White pearl effect  
(Varnish)



■ Chameleon colour (Effect varnish)



● Ruby-Red  
(GRP\*-colour)



■ Electric-Orange pearl effect  
(Varnish)



■ Reflex-Silver pearl effect  
(Varnish)



■ Ruby-Red pearl effect  
(Varnish)



■ Panther-Black pearl effect  
(Varnish)



■ Racing-Blue pearl effect  
(Varnish)

\* glass-fibre reinforced plastic

● Series ■ Special equipment

## Upholstery colours



● Black / Black



■ Black / Grey



■ Black / Red

For printing reasons the bodywork and upholstery colours shown here may vary slightly from the actual colours used.

## Dimensions

Date in millimetres

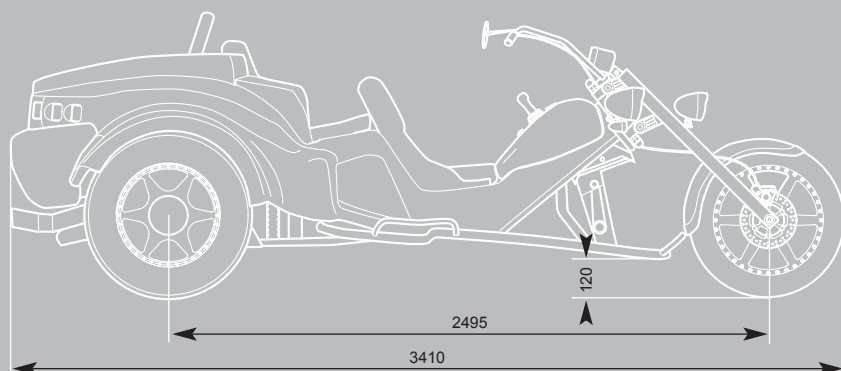
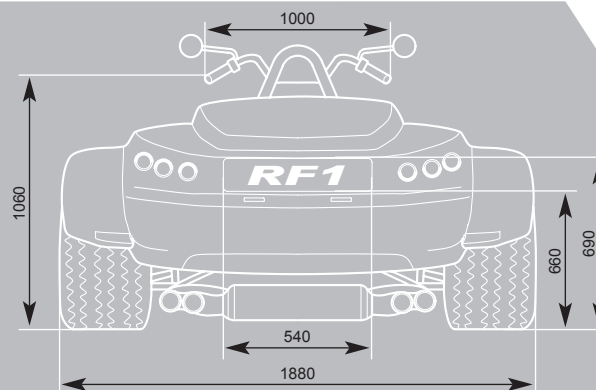



**rewaco**<sup>®</sup> *refreshes your life.*

**TECHNICAL DATA**

### Engine data

Engine	1.6 ltr. 4-cylinder in-line engine with 16 valves
Cubic capacity cm <sup>3</sup>	1596
Max. output KW at min <sup>-1</sup>	85 kW / 6800 (115 hp)
Max. torque at min <sup>-1</sup>	145 Nm / 3200
Exhaust cleaning system	G-cat, Lambda probe

### Power transmission

Gear type	5-gear shift transmission, reverse gear, rear drive
Clutch	Mechanical dry clutch

### Chassis and steering

Front axle	Trapeze steering fork with central spring element
Rear axle	Single wheel suspension with Bilstein gas pressure shock absorbers
Brake system front	Disc brake
Brake system rear	Disc brake
Wheel front	5 J x 17 (optional 5,5 J x 17)
Wheels rear	10 J x 17 (optional 11 J x 18 or 12 J x 18)
Tyre front	180/55 ZR 17 (optional 200/50 ZR 17)
Tyres rear	275/40 ZR 17 (optional 285/35 ZR 18 or 335/30 ZR 18)

### Weight/Volume

Empty weight (kg)	590
Max. load (kg)	210
Tank contents (Ltr.)	40
Seats	2 (1 front + 1 rear)

### Driving performance and consumption

Max. speed (km/h) <sup>1</sup>	174
Acceleration 0-100 (sec.) <sup>1</sup>	6.7
Average consumption (l/100 km) <sup>1</sup>	7 to 10
Fuel	Super unleaded ROZ 95

<sup>1</sup>Driving performance and consumption can deviate depending on the driving style, equipment, road and weather conditions.

The specifications concerning technical data correspond with the state of knowledge available at the time of going to press. The vehicles shown in this catalogue are fitted with special equipment, which is available at an extra charge. No liability is accepted for printing errors. Technical changes may be made without prior notice.

**rewaco** Partner dealership